

Design, Analysis and Fabrication of High Clearance Self-Propelled Foliar Applicator

**Pankaj Malkani^{1*}, Sunil Kumar Rathod¹, K. R. Asha¹, Tapan Kumar Khura¹
and H. L. Khuswaha¹**

¹Division of Agricultural Engineering, ICAR-Indian Agricultural Research Institute, New Delhi-110012,
India.

Authors' contributions

This work was carried out in collaboration among all authors. Author PM designed the study, performed the statistical analysis, wrote the protocol and wrote the first draft of the manuscript. Authors SKR and KRA managed the analyses of the study. Authors TKK and HLK managed the literature searches. All authors read and approved the final manuscript.

Article Information

DOI: 10.9734/CJAST/2020/v39i4831245

Editor(s):

(1) Dr. Elena Lanchares Sancho, University of Zaragoza, Spain.

Reviewers:

(1) Mohamed Ibrahim Elmeadawy, Agric. Eng. Res Inst (AEnRI), Egypt.

(2) Hüseyin Duran, Ondokuz Mayıs University, Turkey.

Complete Peer review History: <http://www.sdiarticle4.com/review-history/60950>

Original Research Article

Received 10 July 2020
Accepted 18 September 2020
Published 31 December 2020

ABSTRACT

In this paper Finite element method (FEM) for design and development of self-propelled foliar applicator is presented. Foliar application is a method for feeding nutrients directly to plants for enhancing nutrient use efficiency through foliar applicator. The major components of the foliar applicator were engine (3.5 kW), gearbox (4F+1R), chassis (1.2 x 0.96 m²), sub-frame assembly, spraying diaphragm pump (Model-SFWP1-055-070-31, capacity 20 l m⁻¹ at 4.4 bar), fertilizer storage tank (225 l). The main objective of this FEM simulation analysis is to find out the stress, deformation and strain induced in chassis and sub-frame assembly of foliar applicator for given boundary condition. A Computer Aided Design of foliar applicator was developed using Creo-parametric 1 software and then analyzed in FEM mode by using Creo simulation1 software. FEM static analysis resulted in maximum von mises stress 200.750MPa and 182.638MPa, maximum deformation 2.81 mm and 1.29 mm and max strain 0.001047 and 0.000636 for chassis and sub-frame assembly respectively. Maximum stresses in both didn't exceed the respective yield points which signified designs, can be used for fabrication.

*Corresponding author: E-mail: pankajmalkani20@gmail.com;

Keywords: Finite element; von mises stress; deformation; chassis; foliar applicator.

1. INTRODUCTION

Fertilizer is among the most used critical inputs for agriculture production system. It provides one or more essential plant nutrient and effect the plant growth. It is applied in either solid form or liquid/aqueous form to the crops. Solid form of application of fertilizers has huge losses [1]. The other method of feeding nutrients to plants is through foliar application. It has high nitrogen use efficiency and easy to spray. The most common method of applying aqueous fertilizers to the field crops in India is through lever operated knapsack sprayer. But due to limitation of non-maintenance of the constant pressure, overall quality and spraying pattern consistency were negatively affected. Bijarniya et al. (2016) had developed a manual tricycle type foliar applicator for Urea ammonium nitrogen (UAN). Two PVC reciprocating type pumps were used to spray chemicals over crops which are powered through the ground wheels. The resultant field coverage of sprayer was considerably low. The other method of application of liquid fertilizers to crop is through sprayer. These sprayers are more reliable, potentially safer and more efficient in use but, majority of these sprayers were tractor operated. It needs high initial investment and cannot be operated in standing narrow row crop. Therefore, these factors restrict their use it for commercial crop like wheat. The aim of this study was to design and fabricate a high clearance self-propelled hydraulic boom foliar applicator for wheat crop. Several researchers used Finite Element (FE) based techniques, a numerical analysis-based tools for the design and optimization of chassis for trailers, trucks, machinery, and for others agricultural implements [2,3,4,5,6,7,8]. A trolley type agrochemical sprayer was developed based upon FEM. The maximum stress and deformation observed on front wheel was 13.948MPa and 0.0000646 mm, while on trolley it was 6.370 MPa and 0.13576mm respectively. These limits were found to be safe for the design of sprayer [7]. In this study a method to design the high clearance self-propelled foliar applicator was presented.

2. MATERIALS AND METHODS

The present study was undertaken for designing, analyzing and fabricating the high clearance self-propelled foliar applicator for narrow row spaced crops.

Design Consideration: For designing the different components geometry modeling, meshing and simulation analysis were done. Geometric model was prepared for foliar applicator.

2.1 Geometric Modeling

The geometric model of the foliar applicator with different views is shown in Fig. 1 and Fig. 2 respectively. Foliar applicator consists of mechanical system and spraying system. Chassis and sub-frame assembly of mechanical system of the foliar applicator was designed and analyzed for its performance. Remaining components were selected based on their physical and mechanical properties. Simulation study was conducted using static analysis for chassis and sub-frame assembly because these were the critical components. The components were prepared in Creo parametric1 and assembled in it. Analysis was carried out through Creo Simulation 1 purchased by Division of Agricultural engineering, IARI, New Delhi.

2.1.1 Mechanical system of foliar applicator

The mechanical system of foliar applicator consisted of power source (engine), chassis, sub-frame assembly, transmission system, tires, steering system, operator seat and braking system.

2.1.1.1 Power source (Engine)

A 5 hp diesel engine (Greaves model-5520, Sr. No; A1E0494383) with maximum engine speed of 3600 rpm was selected for transmitting the power to drive the wheels.

2.1.1.2 Chassis

The chassis for foliar applicator was designed using Creo parametric1 software (Fig. 3a). It holds the entire assembly of the sprayers such as engine, clutch, gearbox, steering system, tank and spraying assembly etc. The chassis was designed using 80 x 40 x 3 mm hollow C tube made of steel with properties shown in Table 1. Overall dimensions (length x width) of chassis were 1.76 m and 0.96 m respectively. Sufficient space was provided for accommodation of engine, gear box, differential and tank. Chassis was provided with 85 cm ground clearance for free passage of foliar applicator over the crop.

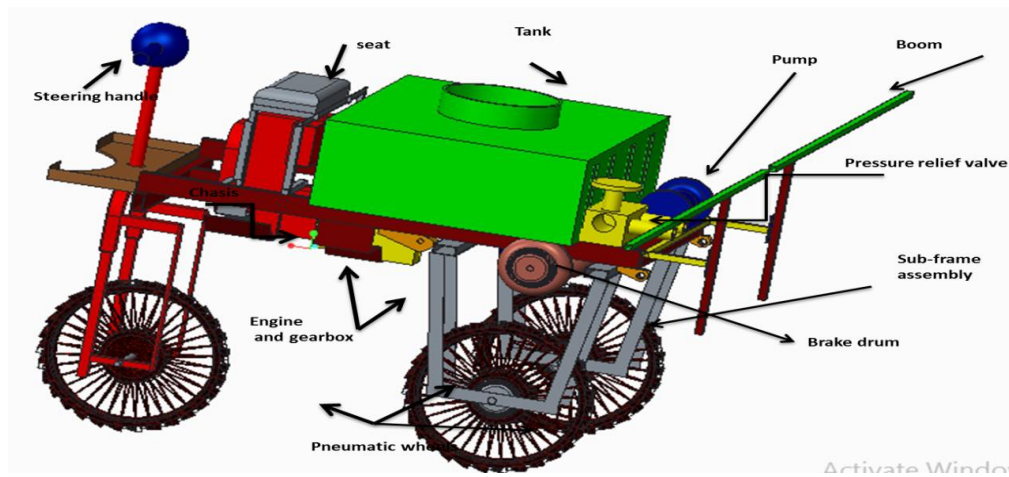

Fig. 1. Geometric model of foliar applicator

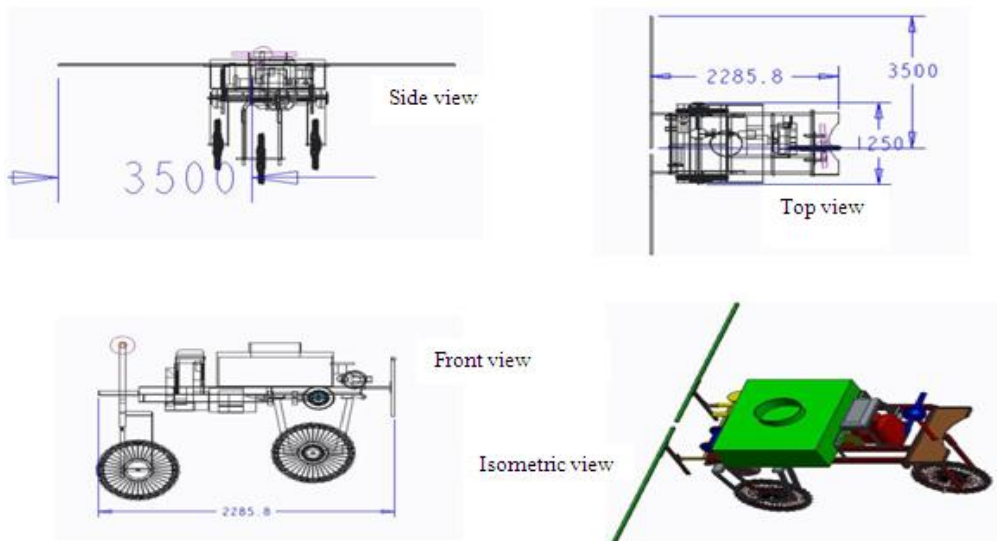

Fig. 2. Different views of self-propelled foliar applicator

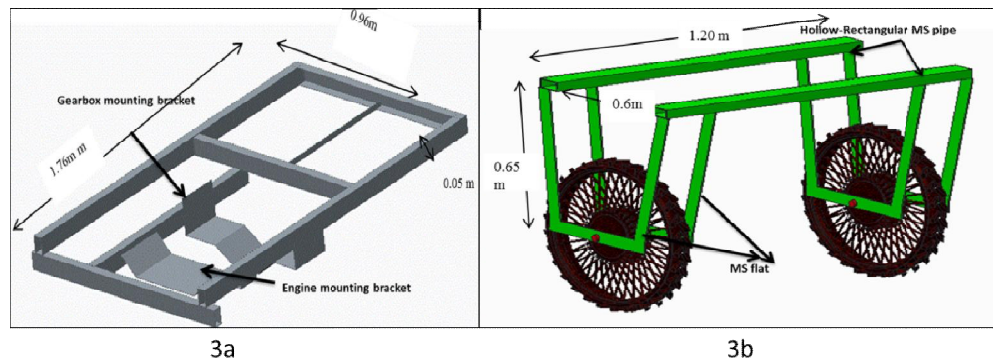

Fig. 3. a. Computer aided design of chassis and b. Sub-frame assembly of foliar applicator
Chain length between wheels and sub-frame assembly

Table 1. Physical and mechanical properties of steel selected for chassis and sub-frame assembly

Specification	Values
Yield strength	250 Mpa
Density	7827Kgm ⁻³
Poisson's ratio	0.27
Young modulus	199.948Gpa

Table 2. Specification of tire

SI No.	Tire size	Rim Dia.(mm)	Section width (mm)	Section height (mm)	Overall Dia. (mm)
1	4"-18"	457.2	100	76.2	610

2.1.1.3 Sub frame assembly

Chassis load was transferred to the wheels through the sub –frame assembly. The drive wheels were mounted on sub main frame assembly (Fig. 3b). Overall dimension of sub-frame assembly was 1.2×0.7×0.7 m (length× width× height). Mild steel material for designing was selected whose physical and mechanical properties were similar to chassis.

2.1.1.4 Transmission system

The power of engine was transmitted to drive wheel with through gearbox, differential system, and chain and sprocket. Gear box with four gear ratio (5:1, 2.93:1, 1.84:1 and 1.12:1) and differential with gear ratio (1:8) were selected. The gearbox had provision for four forward and a reverse speed reduction. The speed was further reduced by the chain sprocket system (V.R=1.36).

The chain with 12.5 mm pitch was selected. Small sprocket (number of teeth 31) was attached to the differential shaft end while large sprocket (number of teeth 43) was attached to the wheel end. The center to center distance between two sprockets was 600 mm and total chain length was calculated from (eq.1) [9].

$$L = \frac{P}{2}(T1 + T2) + 2X + \frac{\left(\frac{P}{2}\operatorname{cosec}\left(\frac{180}{T1}\right) - \frac{P}{2}\operatorname{cosec}\left(\frac{180}{T2}\right)\right)^2}{X} \text{ eq. (1)}$$

Where, L = Length of chain (mm), P = Pitch of chain (mm), T1 = Number of teeth on drive shaft, T2 = Number of teeth on driven shaft, x = Centre to Centre distance between two sprockets

2.1.1.5 Tire

Drive wheel of size 4"-18" was mounted on sub-frame assembly of foliar applicator (Fig. 4a). It was selected for foliar applicator on the basis of recommended wheat crop spacing of 22.5cm. The detail specification is shown in Table 2.

2.1.1.6 Steering system of the foliar applicator

Handle bar type steering mechanism was selected for guiding the foliar applicator. It consisted of Handle bar and a U type frame. Handle bar was directly controlled by operator which rotated the U type frame into an arc and hence, rotating the front wheel.

2.1.1.7 Operator's seat

Seat consisted of seat frame and seat cushion. Seat frame of length, width and height 60× 60× 100 cm respectively was fabricated at workshop from mild steel material and attached to chassis of foliar applicator through nuts and bolts. Sufficient clearance was provided between the seat and handle for operating the foliar applicator.

2.1.1.8 Braking system of the foliar applicator

External expanding type braking system was selected and mounted on rear axles. It consisted of brakes pedal (left and right), mechanical linkages pipe, hydraulic brake oil, master cylinder, brake drum and brake shoe.

2.1.2 Spraying system of foliar applicator

The spraying system of foliar applicator consists of spray tank, boom, pump with pressure relief valve, power source, and spray-nozzles. The tank with moderate capacity (225 l) and non-

corrosive (PVC material) with overall dimension 90×90×40 cm was selected.

2.1.2.1 Nozzles for foliar applicator

Flat fan nozzles are best suitable for foliage spraying [10]. It produced the flat oval spray pattern and has spray angle between 65° to 110°. The nozzles spacing were kept 50 cm based on uniformity of spray pattern obtained at a particular combination of height (50 cm) and pressure (1.5 kgcm⁻²). It has the provision to alter the nozzle spacing based on different combination (Fig. 4b). A total of 14 nozzles were used in the foliar applicator.

2.1.2.2 Boom for foliar applicator

Spray boom consists of flexible pipe guided along the metallic hollow frame of cross-section (25×25×3). Boom pipe was of PVC material selected on the basis of total flow and pressure to be supported. The boom was 7 m in length

split into two equal halves of 3.5 m each and mounted to the chassis at the end. It is provided with height adjuster to vary the height of spray.

2.1.2.3 Pump

Diaphragm type pump (Model-SFWP1-055-070-31, capacity 20 l m⁻¹ at pressure 4.4 kg cm⁻²) was selected based on the pressure requirement to be maintained at the nozzle, type of spray materials to be sprayed and the volume of spray liquid to be delivered per unit time (l/min) [11].

2.2 Meshing

Meshing is the discretization process in which a part is divided into number of nodes and elements. As mentioned earlier, the analysis is carried out for chassis and sub-frame assembly and hence the meshed model for the same is as shown in Fig. (5). The details are shown in Table 3.



Fig. 4. (a) Tire and (b) Flat fan nozzle

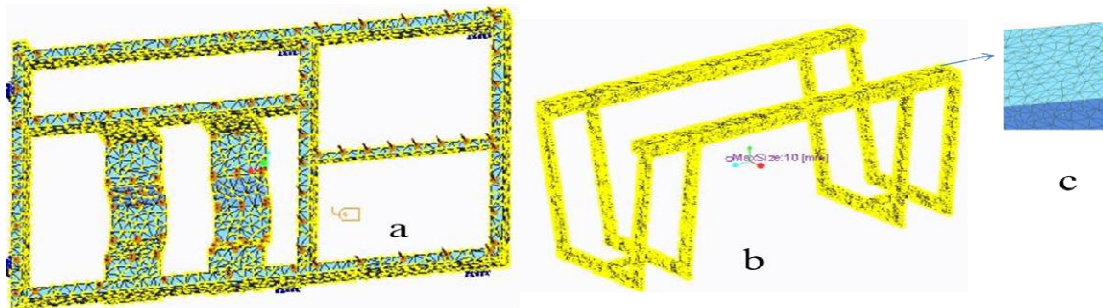

Fig. 5. (a) Mesh structure of chassis; (b) Sub-frame and (c) Cross section of mesh structure

Table 3. Meshing details of chassis and sub-frame assembly

S. No.	Name	Quantity in number(Chassis)	Quantity in number (Sub-frame assembly)
1	Element size	10 mm	10 mm
2	No. of nodes produced	67721	32064
3	No. of elements produced	203280	92557



Fig. 6. Boundary conditions in Chassis

2.3 Simulation Analysis

Analysis was conducted in native bond mode. It was started by assigning the materials to the components. Boundary condition such as constraining and loading is done on the entire model. Geometry was kept fixed for portion retaining the rest structure and forces were applied at the point of contact of loads. The boundary conditions for chassis and sub-frame is shown in Fig. (6) and Fig. (7).

The chassis was kept fixed from 6 surfaces (Bottom side 4 surface (80×40 mm²) and 2 front sides (80×40 mm²)) as shown by blue color. It is loaded with four forces as shown by arrow in different colors. Force on engine bracket (F1=691N), force on gearbox bracket section (F2=491N), force on rear section (F3= 2502N) and force on front section (F4=1472 N).

Total load of the foliar applicator was 700 kg (6965 N). The load applied on sub-frame assembly was 60% of total load (4120N). The load is divided equally on contact points as shown in Fig. (8). The sub-frame assembly was kept fixed from the shaft sides and load was applied from 4 contact surfaces (80×40 mm²).

After imposing the boundary condition static analysis is conducted and Von-Mises stress, deformation and strain in components were determined.

2.3.1 Von-mises stress

For a component to not yield, the developed inner stresses in component should not cross the strength of material. In ductile material, designer is more interested in yield strength because a lasting deformation would comprise failure. Steel is a ductile material and is used for the development of chassis and sub-frame assembly of foliar applicator. The Von-Mises theory is the most appropriate theory for ductile material [12]. Von-Mises stress is calculated by using the equation (2)

$$Von - Mises\ stress(\sigma) = \sqrt{\frac{(\sigma_1 - \sigma_2)^2 + (\sigma_2 - \sigma_3)^2 + (\sigma_1 - \sigma_3)^2}{2}} \tag{2}$$

In equation 2, σ_1 , σ_2 and σ_3 are the principal stresses connected with the three principal directions.

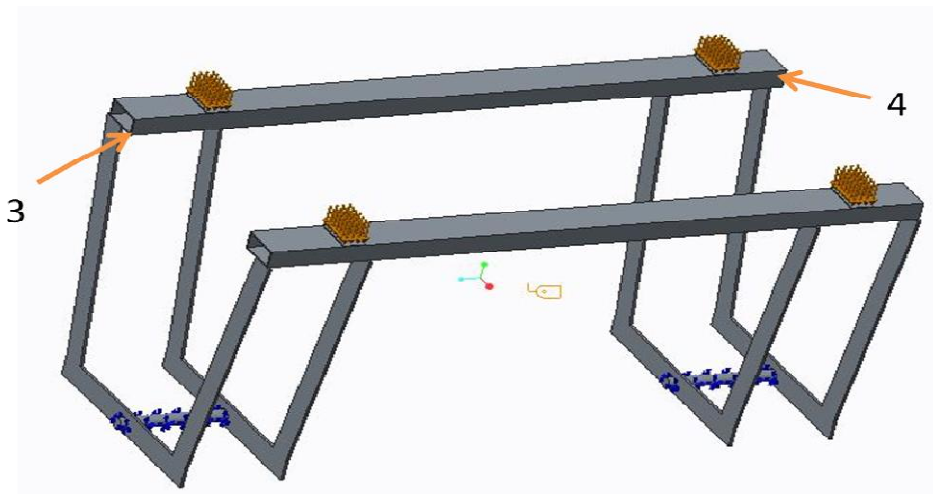

Fig. 7. Boundary conditions for Sub-frame assembly

2.3.2 Deformation

It is the distortion in size and shape of material that occurs when the material is loaded (tensile, compressive etc).

2.3.3 Strain

It is the response of material to the applied stress. It is the ratio of change in length to the total length.

$$\text{Strain} = \frac{\delta L}{L}$$

3. RESULTS AND DISCUSSION

The simulation results for chassis and sub-frame assembly are presented below. These results are based on 3D modeling and numeric methods. FEM analysis saves time, money and energy consumption.

3.1 Analysis of Chassis

Through the Static analysis, the maximum deformation of the chassis occurs at engine bracket and maximum von misses stress developed was 200.750 MPa.

3.1.1 Stress, strain and deformation Analysis

The maximum and minimum principal stresses were 200.750 MPa and near to zero respectively (Fig. 8). Maximum deformation and maximum strain were observed to be 2.81 mm and

0.001047 respectively as shown in Fig. (9) and Fig. (10). The stresses and deformation were more in engine bracket as comparisons to rest of parts but lesser than the yielding strength. Therefore, chassis was considered safe and suitable for fabrication. Similar results were obtained during the development of trolley type manually operated agrochemical sprayer [7]. From this the chassis is good enough for the fabrication purpose. For additional safety the thickness of engine bracket was increased by 1mm to avoid failure.

3.1.2 Displacement vs. curve length

Since, the maximum deformation is seen on the engine bracket. A graph between curve lengths and displacement is presented as shown in Fig. (11). Maximum displacement is observed at a distance of 490 mm from point1 along the engine bracket length as shown in the Fig. (6).

3.2 Analysis of Sub-frame Assembly

Through the Static analysis, the maximum von mises stress occurs at the contact surface. The stress, deformation and strain induced were shown in Figs. (12, 13 and 14) respectively.

The maximum displacement occurs at the center region of point 3 and point 4 shown in Fig. (7). Maximum stresses and strain develop were within the bearable range. Therefore, the developed model can be used for fabrication.



Fig. 8. Stress analysis on Chassis

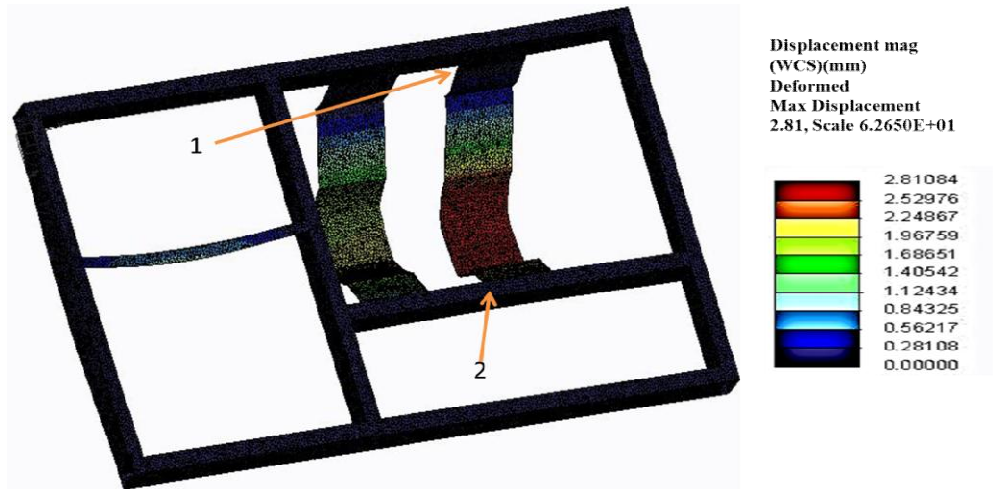

Fig. 9. Displacement Analysis on Chassis

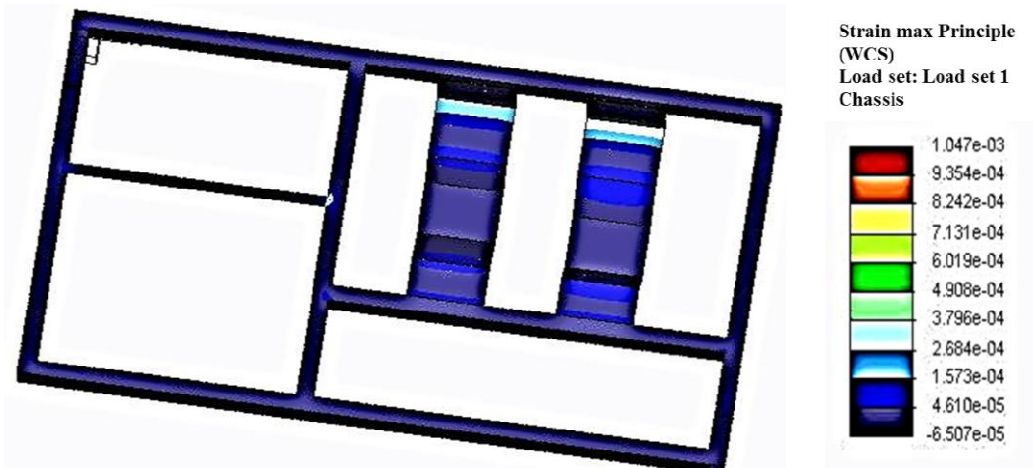

Fig. 10. Strain analysis on Chassis

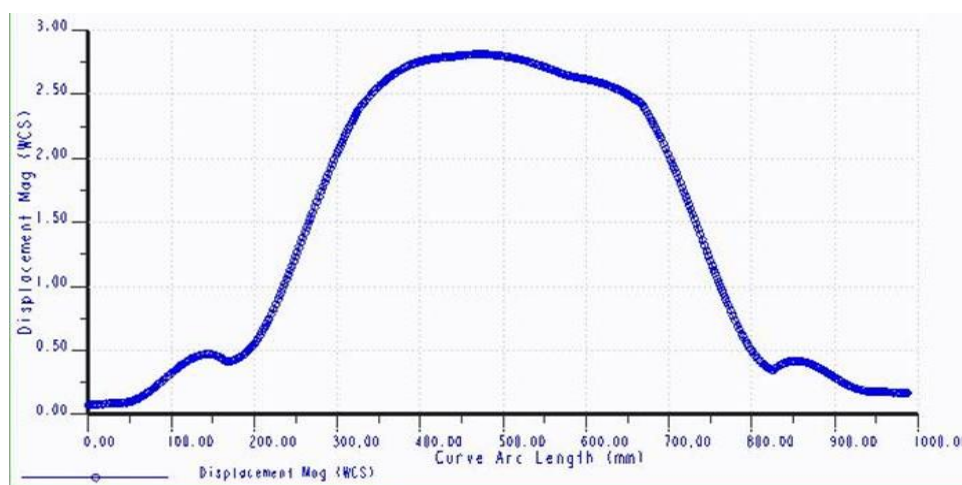

Fig. 11. Displacement curve for chassis of foliar applicator

Table 4. Stress, displacement & strain details of Chassis

Parameters	Numerical result
Maximum stress	182.638 MPa
Maximum deformation	1.29 mm
Maximum strain	0.000636



Fig. 12. Stress analysis on Chassis

3.2.1 Chain length between wheels and frame

Chain length obtained from Equation 1 was 76 inch between chassis and sub-frame for getting desired ground clearance of 85 cm.

3.3 Fabrication, Construction and Working of the Machine

Based on the design and simulation result, the model is fabricated as shown in Fig. (15).

Fabricated was done in the workshop of Division of Agricultural Engineering, ICAR-IARI, New Delhi. The prototype foliar applicator is made basically of the Mechanical (chassis, sub-frame, differential axle, traction wheel, engine etc.) and spraying system (spray tank, pump/prime mover, boom, nozzles and flexible rubber hose) as discussed in earlier section. The chassis supports the spray tank, pump, engine, gearbox and boom assembly etc. Front end of chassis is provided with a single wheel to enhance

maneuverability using handle bar steering system. At the rear end, differential axle is mounted to supply power to the traction wheel attached to the sub-frame assembly. Engine supplies power to the wheels using clutch, gearbox, and differential for developing the traction on the ground. The rear end of chassis also consists of spray tank connected to the nozzles with the help of flexible rubber hose via the pump. The chemical in the spray tank flows by the gravity to the pump which force it with pressure monitored on the pressure gauge to the nozzles. Battery is provided to power to the pump with the help of electric wires.

3.4 Cost Economics

The cost of fabrication of the self-propelled foliar applicator was Rs. 150000.

3.5 Advantage and Limitation of Developed Foliar Applicator

3.5.1 Advantages

- Simple in design, boom is easily foldable and adjustable in height.
- Reasonable cost as compared to other types of engine or tractor operated sprayer
- It saves labor charges and saves tremendous amount of chemical
- Battery operated pump maintains uniform pressure.
- Crops up-to 85 cm height and greater than 12 cm row spacing can be easily sprayed.
- Maintenance cost is lower
- Suitable for crops such as wheat spraying, maize farming, capsicum farming, ground nut farming and for brinjal farming.



Fig. 13. Displacement analysis on Sub-frame assembly

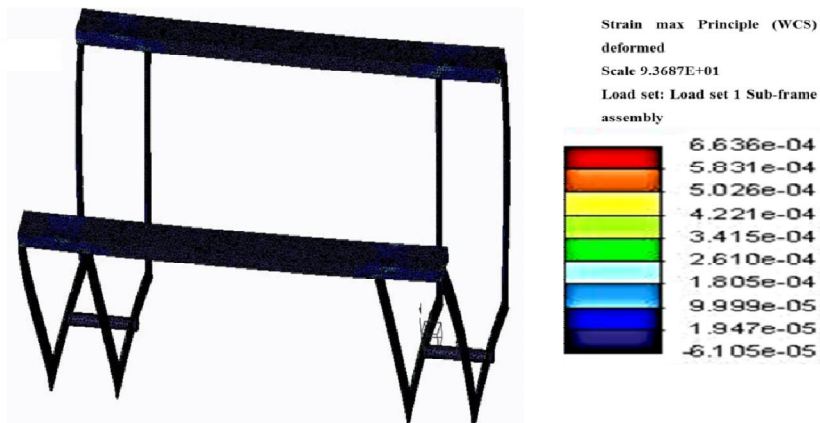

Fig. 14. Strain analysis on Sub-frame assembly



Fig. 15. Actual prototype of high clearance foliar applicator

3.5.2 Limitation

Not suitable for very smaller field.

4. CONCLUSION

Creo parametric 1 and Creo Simulation are very effective and powerful software for designing and analysis of the components. Maximum von mises stresses (200.750MPa & 182.638MPa) and strain (0.001047 & 0.000636) was quite below the yield limits for both chassis and sub-frame assembly respectively. Therefore, the developed model for chassis and sub-frame assembly was accepted for fabrication. The dimensions of foliar applicator were 2.28 m × 1.25 m (length × wide) with ground clearance of 85 cm. Length of boom section was 7 m which could be split into two parts of 3.5 m. This enhance its flexibility while transportation to the field. Also, it is provided with 10 cm wide tires hence can be used for narrow row spaced crop like wheat. The developed applicator was simple and compact in design and had minimum fabrication cost. It will eliminate all labor wages and provides uniform spraying. The fixed cost of the prototype was Rs150, 000. It can be concluded that the present project work becomes a ready reckoner for engineers for future developments in chemicals spraying methods/mechanisms. FEM based methods saved considerable time over hit and trial based method of prototype development.

COMPETING INTERESTS

Authors have declared that no competing interests exist.

REFERENCES

1. Savci S. An agricultural pollutant: chemical fertilizer. *Int. Environ. Sci. Dev.* 2012;3:77–80.
2. Cappello F, Ingrassia T, Mancuso A et al. Methodical redesign of a semitrailer. In: 9th international conference on computer aided optimum design in engineering. *Computer aided optimum design in engineering ix book series: Wit Transactions on the Built Environment.* 2005;80:359–369.
3. De Oliveira MVM, Teixeira MM, Fernandes HC, De Queiroz DM, Moreira RMG. Computer-aided design of a coffee-dragging device. *Semina: Ciências Agrárias.* 2014;35(5):2373-2381.
4. Farhadi P, Mohsenimanesh A, Alimardani R, Ahmadi H. Design and fabrication of a single wheel tester. *Journal of Science and Today's World.* 2013;2(2):123-132.
5. Hoefinghoff J, Jungk A, Knop W, et al. Using 3D field simulation for evaluating UHF RFID systems on forklift trucks. *IEEE Trans Antennas Propag.* 2011;59(2):689–691.
6. Karaoglu C, Kuralay NS. Stress analysis of a truck chassis with riveted joints. *Finite Element Analysis Des.* 2002;38(12):1115–1130.
7. Sagar SB, Punith G, Rakesh CN, Prakash MH, Lakshminarasimha N. Design and development of trolley type agrochemical sprayer. *International e-Journal for Technology and Research.* Conference paper; 2017.

8. Valladares D, Castejon L, Carrera M et al. Comparative analysis of two numerical methods of rollover simulation of a semitrailer for hydrogen transport. In: Proceedings of the ASME international design engineering technical conferences/computers and information in engineering conference, San Diego, CA. 2009;1011–1019.
9. Khurmi RS, Gupta JK. Theory of machines. New Delhi: Eurasia publishing house. 2005;382-414.
10. Bijarniya H. Design and development of foliar applicator for urea ammonium nitrate (Doctoral dissertation, division of agricultural engineering Indian Agricultural research institute New Delhi); 2016.
11. Kaul RN, Suleiman ML. Introduction to crop protection machinery. ABUCONS (nig.) Ltd. Book Series. A.B.U., Press, Zaria, Nigeria. 1990;100.
12. Shigley JE, Mischke CR, Budynas RG, Liu X, Gao Z. Mechanical engineering design. New York: McGraw-Hill. 1989;89.

© 2020 Malkani et al.; This is an Open Access article distributed under the terms of the Creative Commons Attribution License (<http://creativecommons.org/licenses/by/4.0>), which permits unrestricted use, distribution, and reproduction in any medium, provided the original work is properly cited.

Peer-review history:
The peer review history for this paper can be accessed here:
<http://www.sdiarticle4.com/review-history/60950>