



# Review on Microscopic Model of Continuous Pedestrian Flow

Peng Huang <sup>a</sup> and Denghui Liu <sup>a\*</sup>

<sup>a</sup> School of Civil Engineering and Transportation, North China University of Water Resources and Electric Power, Zhengzhou 450045, China.

## Authors' contributions

This work was carried out in collaboration among all authors. Both author read and approved the final manuscript.

## Article Information

DOI: 10.9734/JERR/2022/v23i11753

## Open Peer Review History:

This journal follows the Advanced Open Peer Review policy. Identity of the Reviewers, Editor(s) and additional Reviewers, peer review comments, different versions of the manuscript, comments of the editors, etc are available here: <https://www.sdiarticle5.com/review-history/93319>

**Mini-review Article**

**Received: 10/09/2022**  
**Accepted: 03/11/2022**  
**Published: 07/11/2022**

## ABSTRACT

Continuous pedestrian flow micro model is an important method to study pedestrian flow at present. Compared with macro model and discrete model, continuous pedestrian flow micro model can better simulate pedestrian flow phenomenon. This paper summarizes the research significance and achievements of the continuous pedestrian flow micro model. The research contents and corresponding modeling methods of relevant models are mainly introduced, and the future development of pedestrian flow micro models is prospected.

**Keywords:** Pedestrian flow; continuous model; microscopic model.

## 1. INTRODUCTION

The pedestrian transportation system is an important part of the urban transportation system. In 25 cities with more than one million population in our country, walking accounts for an average of 37.2% in commuting modes, accounting for about 1/3 of the total travel volume [1]. Urban pedestrian traffic has the characteristics of large

flow and high density, and is prone to blockage, push injury, stampede and other problems. Pedestrian flow simulation model plays an important role in the study of pedestrian flow. With the rapid development of computer performance, the microscopic model of pedestrian flow has become the focus of many scholars in the study of pedestrian traffic.

\*Corresponding author: Email: l603823011@163.com;

The microscopic model of pedestrian flow has three main variables: time, space and state. According to their discrete and continuous characteristics, the model of pedestrian flow can be divided into discrete model and continuous model. The discrete model has its essential defect. Its rules are not consistent with the actual walking of pedestrians. Due to the discreteness of time and space, pedestrians are similar to jump from one position to another position in a time step. Therefore, for some specific scenarios, such as relatively fine pedestrian simulation, the continuous model is more suitable than the discrete model. The main idea of continuous model is to establish a dynamic equation to simulate pedestrian movement and study the movement law and evacuation behavior of different elements to pedestrians. The typical microscopic models of continuous pedestrian flow mainly include magnetic force model, social force model [2-4] and self-agent model.

## 2. THE MAGNETIC FORCE MODEL

The Magnetic Force Model was proposed by Okazaki et al. [5-6] and developed continuously from 1979 to 1991. Its principle is to use the electric field force (Coulomb force) acting between two electric charges to simulate the force between pedestrians and between pedestrians and the environment.

A "magnetized" pedestrian in a magnetic field exerts attraction on different poles and repulsive force on the same pole, thus simulating the movement of each pedestrian. In this model, every pedestrian is a positive pole, so are obstacles such as walls, columns and handrails, and the negative pole is assumed to be at the pedestrian's target position. The magnetic force acting on pedestrians is basically calculated by Coulomb's theorem:

$$F = \frac{kq_1q_2r}{||r||^3} \quad (1)$$

Where: F is the electromagnetic force (vector); K is a constant;  $q_1$  is the electromagnetic load intensity of pedestrians;  $q_2$  is the load intensity of the electromagnetic pole; R is the vector of the line between two magnetic poles;  $||r||$  the mold.

To prevent pedestrian collisions, an acceleration  $a$  should also be added:

$$a = VA * \cos a * \tan b \quad (2)$$

The forces of all obstacles and other pedestrians act on each pedestrian, which determines the pedestrian's speed at the next time step. The pedestrian flow and density can also be controlled by changing the magnetic field strength. When the value of the magnetic load strength parameter is large, the repulsive force strength will increase, the distance between pedestrians and other pedestrians and obstacles will be longer, and the pedestrian density and flow will be smaller. On the contrary, the density and flow rate become larger.

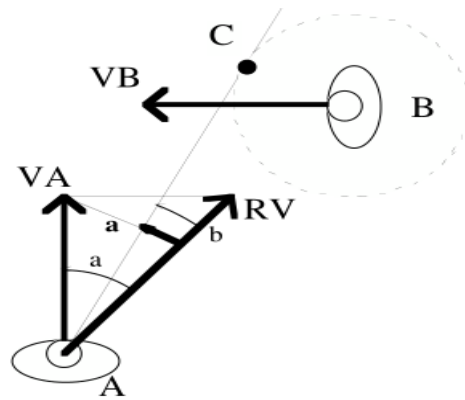

**Fig. 1. Acceleration  $a$  acts on pedestrian  $a$  [3]**  
 In the figure,  $a$  and  $b$  are two pedestrians;  $VA$  is the speed of pedestrian A;  $VB$  is the speed of B pedestrian;  $RV$  is the relative speed of pedestrian A and pedestrian B;  $A$  is the Angle between  $VA$  and  $RV$ ;  $B$  is the Angle between  $RV$  and  $AC$

## 3. THE SOCIAL FORCE MODE

The Social Force Model, first proposed by Helbing in 1995 and continuously developed in the future, is a pedestrian dynamic model recognized by most scholars [7-14]. Helbing [15-16] believes that "social force" is composed of three forces: self-driving force, others' force and boundary force, whose expression is as follows:

$$m_i \frac{dv_i(t)}{dt} = f_i^0 + \sum_{j(\neq i)} f_{jy} + \sum_w f_{jw} \quad (3)$$

Where:  $m_i$  is the body weight of pedestrian  $i$ ;  $\frac{dv_i(t)}{dt}$  is the acceleration of pedestrian  $i$ ;  $f_i^0$  is the pedestrian driving force, and its expression is:

$$f_i^0 = m_i \frac{v_i^0 e_i^0(t) - v_i(t)}{\tau} \quad (4)$$

Where:  $v_i(t)$  is the current speed of pedestrian  $i$ ;  $v_i^0$  is the expected speed of pedestrian  $i$ ;  $e_i^0(t)$  is the expected direction of pedestrian  $i$ .  $\tau$  is the

impromptu acceleration time of pedestrian  $i$ , which is generally fixed;  $f_{ij}$  is the force of others, and its expression is:

$$f_{ij} = \{A_i \exp [(r_{ij} - d_{ij})/B_i + Kg(r_{ij} - d_{ij})]n_{ij} + kg(r_{ij} - d_{ij})\Delta v_{ij}^t t_{ij} \quad (5)$$

Where,  $A_i$  is the strength of non-contact force between pedestrians; Range of action of  $B_i$  repulsive force;  $r_{ij}$  Sum of external dimensions of pedestrian  $i$  and pedestrian  $j$ ;  $d_{ij}$  is the distance between pedestrian  $i$  and pedestrian center point;  $K$  is the strength of the repulsive force of pedestrian body contact;  $K$  is the friction force of pedestrian body contact;  $n_{ij}$  is the direction of the repulsive force between pedestrian  $i$  and pedestrian  $j$ ;  $t_{ij}$  is the direction of friction force, namely the vertical direction of the repulsive force direction.  $\Delta v_{ij}^t$  is the velocity difference between pedestrian  $i$  and pedestrian  $j$  in the tangent direction;  $f_{jw}$  is the boundary force, and its expression is:

$$f_{jw} = \{A_i \exp [(r_i - d_{iw})/B_i + Kg(r_i - d_{iw})]n_{iw} + kg(r_i - d_{iw})(v_i \cdot t_{iw})t_{iw} \quad (6)$$

Where: dimension of  $r_i$  pedestrian  $i$ ;  $d_{iw}$  is the minimum distance from the pedestrian center point to the boundary;  $n_{iw}$  is the boundary repulsive force direction;  $t_{iw}$  is the tangent direction of the boundary curve at the projection point.

The social force model can simulate the crowd evacuation process and the pedestrian traffic situation under general circumstances, and can better reflect the self-organization phenomenon in the current flow of people, which is widely used in the simulation of pedestrian flow. Lakoba et al. [17] developed an algorithm based on explicit numerical integration scheme to solve the problem of simulated pedestrians overlapping each other in physical space. By modifying the social force parameters, Parisi [18] established an automatic stopping mechanism to prevent simulated pedestrians from continuously pushing other pedestrians. Johansson [19] evolutionary optimization algorithm determined the optimal parameter specifications of the social force model. Qu et al. [20] introduced the rotation dynamics to describe the crowding effect, to describe the movement and evacuation dynamics of pedestrians on the stairs. Wang Lei et al. [21] established a self-expected speed function modified social force model to simulate large-scale crowd behavior in emergencies.

#### 4. SELF AGENT MODEL

The Agent-based model can be seen as a complement to the previous model, bringing new functions to pedestrian simulation. With the continuous development of artificial intelligence and computer, Agent has become an important branch in the field of artificial intelligence, and the direction of pedestrian flow also draws on the idea of Agent to create the self-agent model. At present, most of the self-agent models are based on the Agent model of BDI (Belief-Desire-Intention). Schelhorn et al. [22] created and proposed a two-stage model based on Agent to simulate pedestrian behavior in urban streets. Dai et al. [23] regard pedestrians and environment as agents that can interact with each other. The movement direction of pedestrians is affected by four forces: gradient force, repulsive force, resistance and random force. This model can well reproduce the complex phenomenon of real two-way pedestrian flow. D 'Orazio [24] proposed a relevant Agent model to simulate the pedestrian evacuation movement in an earthquake based on the analysis of the video tapes related to real events. Vizzari et al. [25] created an Agent model that can optimize the evacuation path of pedestrians. The self-agent model introduces the pedestrian attribute into the Agent, which can well reflect the details and intelligence of human behavior decision.

#### 5. CONCLUSION

After decades of development, the continuous pedestrian flow micro model has made many achievements, but the pedestrian micro behavior has high complexity, fuzziness and randomness, and the surrounding environment is also diverse, which brings great difficulties to the simulation of pedestrian flow. In addition, pedestrian traffic survey involves a wide range of work. At present, the basic data survey is not sufficient and perfect. Therefore, the survey methods for field experience or test data need to be strengthened. In addition, it is necessary to focus on strengthening the research on crowd behavior parameters and models under different conditions. Therefore, the future pedestrian flow micro model should be built on the basis of a large number of pedestrian flow micro data, combined with multiple disciplines and artificial intelligence.

#### COMPETING INTERESTS

Authors have declared that no competing interests exist.

## REFERENCES

1. Lin Lin, Xue Desheng, Liao Jiangli. Discussion on the pedestrian channel system in Guangzhou central district [J]. *Planner*. 2002;(01):63-65.
2. Farina F, Fontanelli D, Garulli A, et al. Walking ahead: The headed social force model [J]. *PloS One*. 2017;12(1):e0169734.
3. Kretz T. On oscillations in the social force model [J]. *Physica A: Statistical Mechanics and its Applications*. 2015;438:272-285.
4. Yang X, Dong H, Wang Q, et al. Guided crowd dynamics via modified social force model[J]. *Physica A: Statistical Mechanics and its Applications*. 2014;411:63-73.
5. Okazaki S. A study of pedestrian movement in architectural space, part 1: Pedestrian movement by the application of magnetic models [J]. *Trans. AIJ*. 1979;283:111-119.
6. Okazaki S, Matsushita S. A study of simulation model for pedestrian movement with evacuation and queuing [C]. *International Conference on Engineering for Crowd Safety*. 1993:271.
7. Huang L, Gong J, Li W, et al. Social force model-based group behavior simulation in virtual geographic environments [J]. *ISPRS International Journal of Geo-Information*. 2018;7(2):79.
8. Sticco IM, Frank GA, Dorso CO. Social force model parameter testing and optimization using a high stress real-life situation [J]. *Physica A: Statistical Mechanics and its Applications*. 2021;561:125299.
9. Marlow F, Jacob J, Sagaut P. A multidisciplinary model coupling Lattice-Boltzmann-based CFD and a Social Force Model for the simulation of pollutant dispersion in evacuation situations [J]. *Building and Environment*. 2021;205:108212.
10. Sun Y, Liu H. Crowd evacuation simulation method combining the density field and social force model [J]. *Physica A: Statistical Mechanics and its Applications*. 2021;566:125652.
11. Zhao Y, Liu H, Gao K. An evacuation simulation method based on an improved artificial bee colony algorithm and a social force model [J]. *Applied Intelligence*. 2021; 51(1):100-123.
12. Liu Q. A social force model for the crowd evacuation in a terrorist attack [J]. *Physica A: Statistical Mechanics and its Applications*. 2018;502:315-330.
13. Taherifar N, Hamedmoghadam H, Sree S, et al. A macroscopic approach for calibration and validation of a modified social force model for bidirectional pedestrian streams [J]. *Transportmetrica A: Transport Science*. 2019;15(2):1637-1661.
14. Gil Ó, Garrell A, Sanfeliu A. Social robot navigation tasks: Combining machine learning techniques and social force model [J]. *Sensors*. 2021;21(21):7087.
15. Helbing D, Molnar P. Social force model for pedestrian dynamics [J]. *Physical Review E*. 1995;51(5):4282.
16. Helbing D, Farkas I, Vicsek T. Simulating dynamical features of escape panic [J]. *Nature*. 2000;407(6803):487-490.
17. Lakoba TI, Kaup DJ, Finkelstein NM. Modifications of the Helbing-Molnar-Farkas-Vicsek social force model for pedestrian evolution [J]. *Simulation*. 2005; 81(5):339-352.
18. Parisi DR, Gilman M, Moldovan H. A modification of the social force model can reproduce experimental data of pedestrian flows in normal conditions [J]. *Physica A: Statistical Mechanics and its Applications*. 2009;388(17):3600-3608.
19. Johansson A, Helbing D, Shukla PK. Specification of the social force pedestrian model by evolutionary adjustment to video tracking data [J]. *Advances in Complex Systems*. 2007;10(supp02):271-288.
20. Qu Y, Gao Z, Xiao Y, et al. Modeling the pedestrian's movement and simulating evacuation dynamics on stairs [J]. *Safety science*. 2014;70:189-201.
21. Wang Lei, CAI Yun, Xu Qing. Research on the improvement of Social force Model [J]. *Journal of Nanjing University of Science and Technology: Natural Science Edition*, 2011, 35(1): 144-149.
22. Schelhorn T, O'Sullivan D, Haklay M, et al. *Streets: An agent-based pedestrian model [J]*; 1999.
23. Dai J, Li X, Liu L. Simulation of pedestrian counter flow through bottlenecks by using an agent-based model [J]. *Physica A: Statistical Mechanics and its Applications*. 2013;392(9):2202-2211.

24. D’Orazio M, Spalazzi L, Quagliarini E, et al. Agent-based model for earthquake pedestrians’ evacuation in urban outdoor scenarios: Behavioural patterns definition and evacuation paths choice [J]. Safety science. 2014;62:450-465.
25. Vizzari G, Crociani L, Bandini S. An agent-based model for plausible wayfinding in pedestrian simulation [J]. Engineering Applications of Artificial Intelligence. 2020;87:103241.

---

© 2022 Huang and Liu; This is an Open Access article distributed under the terms of the Creative Commons Attribution License (<http://creativecommons.org/licenses/by/4.0>), which permits unrestricted use, distribution, and reproduction in any medium, provided the original work is properly cited.

*Peer-review history:*

*The peer review history for this paper can be accessed here:*  
<https://www.sdiarticle5.com/review-history/93319>